

A - A

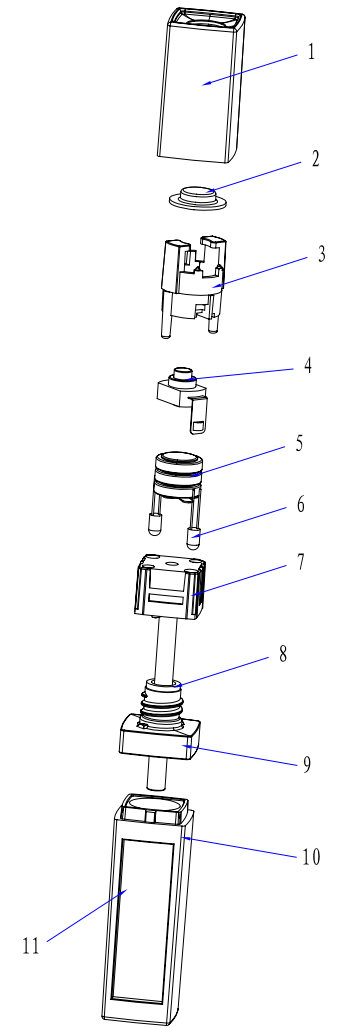
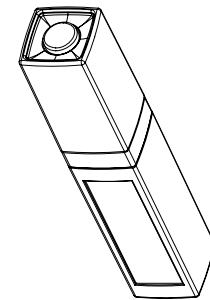

11	Mirror	1	GLASS
10	Bottle	1	AS
9	Neck	1	AS
8	Wiper	1	TPR
7		1	POM
6	LED Lamp	2	
5	Battery	3	
4	Button switch	1	
3	LED Lamp Holder	1	ABS
2	Button spacer	1	Rubber
1	Cap	1	AS+ABS
ITEM NO.	PART NAME	Q'TY	MATERIAL

NO.	DATE	MODIFY NO.	CONTENT FOR REVISION		REMARKS
TOLERANCES OTHER		PRT NAME	PRT NO.	GCML170	WEIGHT
DIM VALUE	TOL	LVALUE	DARW	PART NO.	MAT'L
0--10 mm :	±	0.06 mm	CHECK	MOLD NO.	SHRINK
10--30 mm :	±	0.12 mm	AUDITING	MOLD CAV	UNIT
30--50 mm :	±	0.16 mm	APPROVE		MM
50 OVER mm :	±	0.20 mm			
PROJECTION		DWG DATE	2012-6-14		